

UNTERLINDEN



BY
HERZOG & DE MEURON



Artemide®



HERZOG & DE MEURON

Jacques Herzog and Pierre de Meuron, established their practice in 1978 in Basel, Switzerland. Now numbering close to 500 collaborators with offices worldwide, the partnership has designed award-winning spaces for cultural organizations, hotels, museums, residences and sports stadiums.

Known for transforming traditional architectural materials through innovative treatment and complex geometric expression yet retaining a focus on the essentials of design, among their best-known projects are The Tate Modern, Beijing's Olympic Stadium, Prada Tokyo and Miami's 1111 Lincoln Road.

Amongst other awards, they are the recipients, in 2001, of The Pritzker Architectural Prize.





ELEGANCE

Unterlinden, originally designed by Herzog & De Meuron for the Unterlinden Museum in Colmar (France) renovation, combines the aesthetic charm of an old-time object with high technology and engineering.



TECHNOLOGY

A high-performance LED COB and high-efficiency optic polymeric lens ensure a very high quality of light. Unterlinden's body has been specifically designed to allow for heat dissipation as well as to direct the luminous flow downwards.

UNTERLINDEN Table

EMISSION

direct

LIGHT SOURCE

LED

6W C.O.B 3000K >90CRI

or

6W C.O.B 2700K >90 CRI

DELIVERED LUMENS

359lm

DIMMING FEATURE

dimnable (on head)

DIMENSIONS

12"
30.4 cm



20 1/4"
51.6 cm

6 1/4"
16 cm

FINISH

- aluminum
- bronze

CERTIFICATIONS

c.UL.us listed, LM-79, IP20



UNTERLINDEN Suspension

EMISSION
direct

LIGHT SOURCE
LED
6W C.O.B 3000K >90CRI
or
6W C.O.B 2700K >90 CRI

DELIVERED LUMENS
615lm

DIMMING FEATURE
ON/OFF

DIMENSIONS

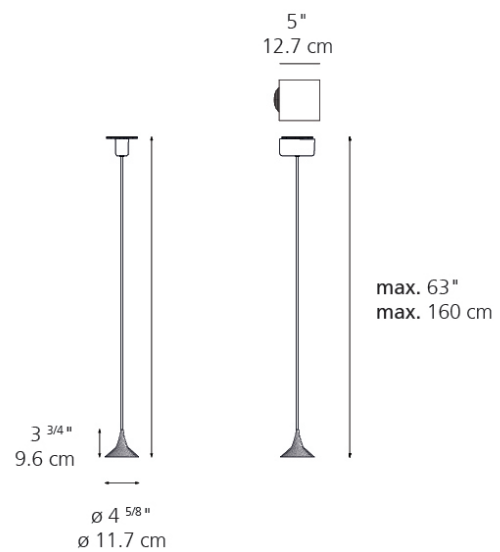

FINISH

aluminum
bronze

Fabric cord in black for aluminum finish and in white for bronze finish.

CERTIFICATIONS
c.U.L.us listed, IP20



For retail sales contact information, please visit
www.artemide.net/store-locator



For contract sales contact information, please visit
www.artemide.net/contract-sales